

# ***TCX450 Tire Changer***

***Manual Swing-Arm Design***



- Side Swing Mounting Arm
- Self-Centering Chuck
- Adjustable, Side-Mounted Bead Loosener

***HUNTER***  
***Engineering Company***

# TCX450 Tire Changer

## Tire Changer Features

- Side swing mounting arm.
- Mechanical adjustment of the mounting arm.
- Self-centering four-jaw clamping system.
- Two pneumatic clamping cylinders.
- Clockwise and counterclockwise rotation of the turntable using an electric motor.
- Equipped with an inflation limiting valve (CE norms).
- Pressure regulator with water filter and lubricator.
- Polymer inserts to protect alloy rims.

## TCX450 Standard Accessories



**Tire paste, paste brush, bead lever and kit of plastic protectors for alloy rims**

## TCX450 Optional Accessories



**ASTURO tire inflating gun-&gauge (CE norms)**



**Mechanical bead press roller**



**Set of adaptors to reduce outside clamping diameter by 2 inches**



**Drop-center mounting clamp**



**Set of adaptors to increase outside clamping diameter by 4 inches**



**Universal quick change device for tool-heads**



**Set of motorcycle wheel adaptors**



**Polymer mount/demount head**



**Set of adaptors to reduce outside clamping diameter by 4 inches**



**Mount/demount head for convex-spoke rims (VW) complete with polymer inserts to protect alloy rims**

*For other accessories see separate catalog.*

## TCX450 Specifications<sup>†</sup>

- Air Pressure Operating Range 8-10 Bar (115-145 Psi)
- Wheel Clamping (nominal)
  - External Clamping (min-max) 10 in. - 19 in.,
  - Internal Clamping (min-max) 12 in. - 21 in.
- Maximum Tire Diameter 1,000 mm (40 in.)
- Maximum Tire Width 310 mm (12 in.)
- Bead Loosener Range 45 - 320 mm (1.8 - 12.6 in.)
- Machine Weight 163 kg. (359 lbs.)

### Available Models

All models are manual swing-arm tire changers with 1-speed electric motors

Part No.	Power Requirements
TCX450-2-3-U	230/400V-3ph-50/60hz
TCX450-2-1-5	230V-1ph-50hz
TCX450-2-1-6	230V-1ph-60hz

### Standard Accessories

- Bead Lever
- Bead Lever Protectors
- Clamping Jaw Protectors
- Mount/Demount Head Inserts
- Shovel Protectors
- Brush
- 5kg Tire Paste

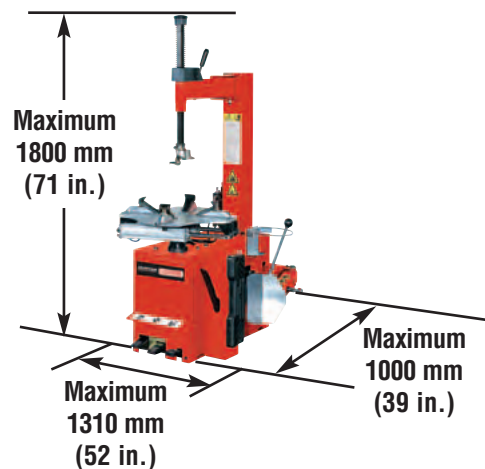

Visit our Website: [www.hunter.com](http://www.hunter.com)

**HUNTER**  
Engineering Company

11250 Hunter Drive, Bridgeton, MO 63044 U.S.A.  
Tel: 1-314-731-3020 • FAX: 1-314-731-0132  
E-mail: [international@hunter.com](mailto:international@hunter.com)

<sup>†</sup> Some dimensions, capacities and specifications may vary depending on tire and wheel configurations. Because of continuing technological advancements, specifications, models and options are subject to change without notice.